



Designation: C167 – 22

Standard Test Methods for Thickness and Density of Blanket or Batt Thermal Insulations¹

This standard is issued under the fixed designation C167; the number immediately following the designation indicates the year of original adoption or, in the case of revision, the year of last revision. A number in parentheses indicates the year of last reapproval. A superscript epsilon (ϵ) indicates an editorial change since the last revision or reapproval.

This standard has been approved for use by agencies of the U.S. Department of Defense.

1. Scope

1.1 These test methods cover the determination of thickness and density of flexible, felted, or woven thermal insulating blankets, rolls, or batts composed of fibrous materials, with or without surface covering or reinforcement.

1.2 The values stated in inch-pound units are to be regarded as standard. The values given in parentheses are mathematical conversions to SI units that are provided for information only and are not considered standard.

1.3 *This standard does not purport to address all of the safety concerns, if any, associated with its use. It is the responsibility of the user of this standard to establish appropriate safety, health, and environmental practices and determine the applicability of regulatory limitations prior to use.*

1.4 *This international standard was developed in accordance with internationally recognized principles on standardization established in the Decision on Principles for the Development of International Standards, Guides and Recommendations issued by the World Trade Organization Technical Barriers to Trade (TBT) Committee.*

2. Referenced Documents

2.1 *ASTM Standards:*²

[C168 Terminology Relating to Thermal Insulation](#)

[E2935 Practice for Evaluating Equivalence of Two Testing Processes](#)

3. Terminology

3.1 *Definitions*—Terminology [C168](#) shall be considered as applicable to the terms used in these test methods.

¹ These test methods are under the jurisdiction of ASTM Committee [C16](#) on Thermal Insulation and are the direct responsibility of Subcommittee [C16.32](#) on Mechanical Properties.

Current edition approved Nov. 1, 2022. Published December 2022. Originally approved in 1941. Last previous edition approved in 2018 as C167 – 18. DOI: 10.1520/C0167-22.

² For referenced ASTM standards, visit the ASTM website, www.astm.org, or contact ASTM Customer Service at service@astm.org. For *Annual Book of ASTM Standards* volume information, refer to the standard's Document Summary page on the ASTM website.

3.2 Definitions of Terms Specific to This Standard:

3.2.1 *package*—an individually wrapped group or bag of batts or a single roll of thermal insulation material.

4. Significance and Use

4.1 Proper measurements of thickness and density of blanket or batt insulations are essential for determining thermal insulation properties. For a particular batt or blanket product, thickness and density are usually directly related to thermal insulating value.

4.2 These test methods are of significant value in manufacturing quality control, to ensure that claimed insulation values of products are maintained.

5. Apparatus

5.1 *Depth Gauge*, of the type shown in [Fig. 1](#). The disk shall be fabricated of a suitable plastic material. The disk shall have a mass of 9.3 ± 0.3 grams and shall exert a pressure of 0.4 lbf/ft^2 (20 Pa). The disk shall be 3-in. \pm 0.08-in. (76 mm \pm 2mm) in diameter. The disk shall be perpendicular to the pin at all times and shall have a friction device or thumb grip to secure the pin unless purposely moved. The pin shall be made at a maximum $\frac{1}{8}$ -in. (3 mm) diameter. The pin shall be of sufficient length for the material to be measured.

5.2 *Steel rule*, graduated in 0.05-in. or 1-mm intervals.

5.3 *Scales*, of sufficient capacity and sensitivity to weigh the test specimen to an accuracy of ± 0.5 %.

5.4 An alternative thickness measurement technique is considered acceptable if the alternative method and depth gauge presented in [5.1](#) meet the means equivalency analysis as directed in Section 7 of Practice [E2935](#). The equivalence limit of 0.2 in., a confidence level of 95 %, and minimum sample size of 50 shall be used in the equivalency analysis. The equivalence analysis must cover the range of thickness for which it will be used.

6. Sampling

6.1 A test sample shall consist of one representative roll or package of insulation.

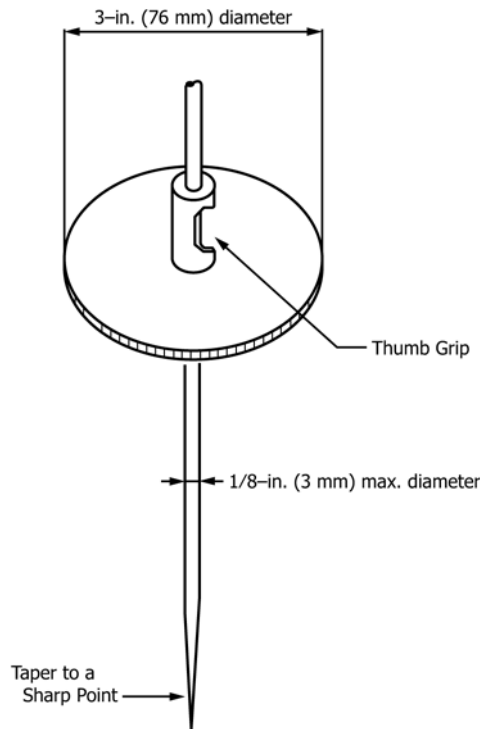

FIG. 1 Depth Gauge for Thickness Measurements

6.2 *Sampling of Packages*—For packages which contain 20 or more batts, five batts shall be selected. For packages which contain less than 20 batts, either the three-batt or five-batt selection technique may be used. Batts which are folded in half shall count as two batts for purposes of choosing and employing the selection method.

6.2.1 *Three-Batt Method*—Select the center batt and the second batt in from each end of the package.

6.2.2 *Five-Batt Method*—Divide the package sequentially into five groups of batts as equal in number as possible. Select the first batt from each group. Be careful to select one and only one batt from the two end batts within the package.

6.2.3 Cut batts which are longer than 48 in. to 48 ± 0.25 in. (122 ± 0.63 cm) in length.

6.3 *Sampling of Cut Rolls*—Five batts shall be cut of roll-width by 48 ± 0.25 in. (122 ± 0.63 cm) in length.

6.3.1 Cut one batt from the center of the roll, two batts from the ends of the roll, and the fourth and fifth from the quarter points along the length. See Fig. 2.

6.3.2 For blankets wider than 24 in., cut each of the five batts 24 ± 0.25 in. (61 ± 0.63 cm) wide by 48 ± 0.25 in. (122 ± 0.63 cm) long.

6.4 *Sampling for Full Roll Method*—Subsection 7.6 is acceptable to use in place of 6.3 when the roll is wider than 24 in. (61 cm) or longer than 50 ft (16.4 m).

7. Procedure

7.1 *Expansion of Packages and Cut Roll*—Hold the first batt vertically off the floor by grasping it with both hands on its long dimension so that the lower edge is 18 ± 1 in. (460 ± 25 mm) above a solid horizontal surface. Release the batt, allowing it to strike the surface. Repeat the above for a second time. Next, holding the batt by the other long edge, drop twice as above. Place the specimen on the flat, hard surface. Repeat the above for the remaining four specimens. Allow specimens to reach equilibrium by waiting at least 5 min before making thickness measurements within 1 in. (25 mm) in any direction of five points as indicated in Fig. 3.

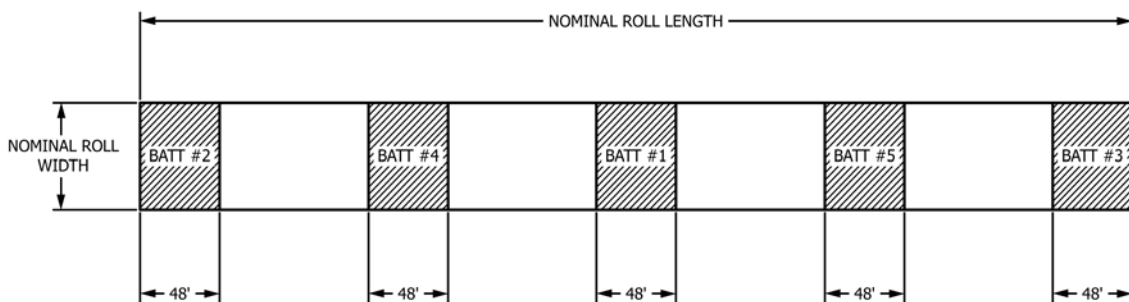

FIG. 2 Sampling of Cut Rolls